

Cobra Vintage Bike Service / Parts Manual

BM 1994 – '97

CM 1997 – '02

King 1997 – '02



“CHAMPIONS START HERE”

“WARNING”

THIS BIKE IS A COMPETITION MODEL ONLY AND IS NOT MANUFACTURED FOR, NOR SHOULD IT BE USED ON PUBLIC STREETS, ROADS OR HIGHWAYS. THE USE OF THIS BIKE SHOULD BE LIMITED TO PARTICIPATION IN SANCTIONED COMPETITION EVENTS UPON A CLOSED COURSE. THIS BIKE SHOULD NOT BE USED FOR GENERAL OFF-ROAD RECREATIONAL RIDING. THIS BIKE IS INTENDED FOR EXPERIENCED RACERS ONLY AND NOT FOR BEGINNERS.

IT IS YOUR RESPONSIBILITY TO KEEP YOUR BIKE IN A SAFE OPERATING CONDITION.

DISCLAIMER OF WARRANTY

THIS MOTORCYCLE IS SOLD “AS IS” WITH ALL FAULTS, OBVIOUS OR CONCEALED. THERE ARE NO WARRANTIES EXPRESSED OR IMPLIED, INCLUDING ANY WARRANTY OF MERCHANTABILITY AND WARRANTY OF FITNESS FOR ANY PARTICULAR PURPOSE.

BREAK-IN PROCEDURES

Your Cobra is equipped with a close-tolerance high performance engine and break-in time is very important for maximum engine life and performance. This engine takes at least 6 hours of break-in time before it starts to loosen up and run at an optimal performance level. We recommend running a 32: 1 fuel mixture during the break-in period. Allow the engine to run on the rich side during this break-in time.

Please note: It is normal for bikes equipped with radiators to overflow and lose approximately 1/4 to 1/2 cup of anti-freeze during this period. It is very important that your radiator cap is on correctly and is holding pressure. Radiator pressure is what makes the anti-freeze circulate, so it is very important that there is no leakage of pressure. You must remove the radiator shroud to get to the radiator cap. Use a 2.5mm Allen wrench on button head screws to remove radiator shroud.

The engine transmission oil should be changed after the initial 1 to 2 hours of use. See “specifications” for proper fluid type.

The fork and shock oil should be changed after the initial 9 hours of use. See “specifications” for proper fluid type.

After the first hour running time, all bolts should be re-tightened or re-torqued including head bolts, crankcase bolts, kick starter cover bolts, stator bolts, motor mounts and intake manifold bolts.

Clean the carburetor bowl after the first hour of use.

START UP MAINTENANCE SHEET

1. **BEFORE EACH USE, REMOVE THE COVER PLATE OF THE THROTTLE ASSEMBLY AND CHECK THE THROTTLE CABLE FOR FRAYING. IF THE CABLE SHOWS ANY SIGNS OF WEAR, FRAYING OR UNWINDING, REPLACE BEFORE USE. ALSO CHECK THE CABLE FOR STICKING OR PINCHING ON THE FRAME. IF THE CABLE DOES NOT WORK SMOOTHLY, REPLACE BEFORE USE. IT IS RECOMMENDED THAT THE THROTTLE CABLE BE REPLACED AT LEAST ONCE A MONTH.**
2. Change engine transmission oil every 2 to 3 hours. See “specifications” for proper fluid type. Fill to hole.
3. Change fork and shock oil every 9 hours. See “specifications” for proper fluid type.
4. Keep all moving parts sprayed with WD-40 or light oil.
5. Keep ignitions clean and dry. Spray with WD-40. It is *very important* to keep the ground wire going from the frame to the engine clean and connected.
6. Check all nuts, bolts and screws for proper torque.
7. Check the chain for proper adjustment. See “chain tension” section for details.
8. We recommend 15 pounds of pressure in the rear tire in rainy and muddy conditions and 20 pounds on hard packed conditions or where there are a lot of jumps.
9. INSPECT:
 - chain rollers
 - swing arm for stress cracks or signs of fatigue
 - frame for stress cracks or signs of fatigue
 - wheels for cracks and signs of fatigue
 - handle bar clamps
 - make sure kill switch works
 - make sure engine is running properly and the carburetor jetting is set correctly

OPERATIONAL TIPS

1. Pull up choke and turn it to lock it, then start the engine. Raise the rear wheel off the ground and rev in short spurts, turning the throttle no more than 1/8 to 1/4 turn on the throttle until the engine will run without the choke. The engine is properly warmed when the side of the cylinder is warm to touch. **NEVER** rev an engine full throttle when it's cold or slightly warmed up. We recommend you tell your child to take it easy the first couple of minutes in practice until the engine comes up to full operating temperature. Make sure your engine is properly warmed up before racing.
2. Because of the amount of heat generated by the clutch and engine during extended periods of riding, it is advisable to remove the ignition cover afterward to allow the ignition to cool off. The heat transfers through the cases and can damage the stator as it cools off because of lack of airflow around the stator.
3. If your kick starter lever does not return to the rubber bumper, use WD-40 or a light penetrating oil under the plastic cover behind the spring on the shaft. The shaft is a very close fit to the case and also has an O ring in it and is difficult to get lubrication to which may cause binding. If it does not loosen up, remove the kick-starter cover and kicking assembly. Grease the shaft.
4. Foot brake--make sure your riders foot is not resting on the foot brake while they are riding.
5. Do not over tighten the handle bar clamps. Over tightening the clamp will cause premature failure.
6. Watch for bending and warping of the outside rear damper plate. If it is bent or warped, the rubber dampers in the sprockets do not last as long. Usually you can straighten the plate with a hammer or just flip it over.
7. You should strain your gas through a fine micro filter because gas stations use a fiber filter and sometimes the fibers come out in the gas and they will clog your pilot jet. The pilot jet in the Cobra is very small and clogs very easily.
8. If you ever need to weld anything on the bike, disconnect the spark plug cap, unplug the ignition, disconnect the kill switch, scrape the paint bare near the area to be welded and put the ground clamp as close to the area to be welded as possible. The frame is 4130 Chrome Moly and it is important to weld it with the proper rod and heat settings set as light as possible.
9. DO NOT USE ANY KIND OF RACING FUEL! All our testing was done with 93 octane pump gas. We run 32:1 up to 40:1 using a good grade of synthetic premix or our special blend of Cobra Venom.

AIR FILTER

The Cobra is equipped with a special designed sock filter. It is very important to keep it clean and properly oiled with high quality water-resistant foam filter oil. Its very important to oil your filter consistently each time because varied amounts of oil will change your carburetor jetting.

Make sure you change your filter after each moto. We recommend carrying 3 filters in your toolbox. 1 for practice, 1 for the first moto and 1 for the second moto. In our testing when filters are properly oiled, no water, dirt or mud can penetrate through to the carburetor inlet. It is important that the filter does not touch any of the frame components in a rainy, muddy situation. We also carry filters for use in the sand (part # RCMU0101).

When washing your bike cover the carburetor/filter with a suitable shield capable of keeping water from entering the engine. Cobra has a rubber clamp-on plug for the carburetor referred to as a carb condom (part # RCMU0104).

CHAIN

Do not use heavy chain lubes typically used on full sized off road motorcycles. Using heavy lubes will rob a significant amount of horsepower. We recommend using light oil or WD-40.

Excessive chain slop may cause serious engine damage. When the chain is loose, it causes a whiplash effect to the internal moving parts of the engine and also robs horsepower. It is very important the chain is checked and adjusted before every moto.

For all 1997-99 CM models and all 1994-97 BM models equipped with spring loaded chain tensioners: To properly check the chain tension stand on the right side of the bike (kick starter side). Use your left knee on the seat to collapse the suspension so the swing arm legs are parallel to the ground. This is the point of maximum chain tension throughout the suspension stroke. Reach down and move the spring-loaded tensioner off the chain. With the tensioner off the chain, the chain tension should have very little play. (NOT TIGHT—NOT LOOSE). Loosen the rear wheel and make the proper wheel adjustments, making sure the wheel is straight. To align the rear wheel, ensure that the measurement from the end of the swing arm to the rim is the same on both sides. Retighten the axle and check the chain tension again.

For the 2000-02 CM & '97 – '02 King: This bike is not equipped with the spring-loaded chain tensioner. To properly check the chain tension stand on the right side of the bike (kick starter side). Use your left knee on the seat to collapse the suspension so the swing arm legs are parallel to the ground. This is the point of maximum chain tension throughout the suspension stroke. The chain tension should have very little play. (NOT TIGHT—NOT LOOSE). Loosen the rear wheel and make the proper wheel adjustments, making sure the wheel is straight. To align the rear wheel, ensure that the measurement from the end of the swing arm to the rim is the same on both sides. Retighten the axle and check the chain tension again. The chain guide is adjustable from front to back. Make sure it is not rubbing the sprocket or binding the chain. Loosen the (2)-6mm bolts and make the proper adjustments. The bottom chain guide has a replaceable center

slider. It is part # PCKG0004. The front roller wheel with the 2 cotter pins and 2 washers is part # FAMU0002.

REAR WHEEL DAMPING

The Cobra is the only 50cc to have the patented rear wheel damping system. This feature prevents engine impact shock caused by hard landings. This design allows the cushioned sprocket to move forward and backwards separately from the wheel. After each moto, check the 4 rubber dampers, spacers and bolts for fatigue. You should keep extra rubber dampers in your toolbox (part # PCMU0059). Different sized sprockets are also available.

Watch for bending and warping of the outside rear damper plate. If it is bent or warped, the rubber dampers in the sprockets do not last as long. Usually you can straighten the plate with a hammer or just flip it over.

STATOR CARE

Stator failure will result from running the bike hot. Following is a list of things that will make your engine run hot.

- 1) The timing should not exceed the maximum specifications listed.
- 2) Improper Carburetor jetting.
- 3) Improper spark plug heat range. Never run a hotter plug than the specified spark plug.
- 4) Clutch slippage. See "CLUTCH" section for causes of slippage.

Because of the amount of heat generated by the clutch and engine during extended periods of riding, it is advisable to remove the ignition cover afterward to allow the ignition to cool off. The heat transfers through the cases and can damage the stator as it cools off because of lack of airflow around the stator. Spray the stator and rotor with CRC 3-36 or WD-40 and let it drip dry or blow it off a little with an air nozzle.

Ignition will overheat if there is not enough gap between the rotor and stator. There should be 0.020 clearance on both sides.

The rotor magnet is NOT KEYED to the crankshaft. If it is removed you MUST have a dial indicator to reset the timing on the pre 2001 CM models.

Non-resistor spark plug caps should be used. Resistor caps will work but they will result in a weaker spark that will reduce performance.

Make sure connections are free of dirt.

Make sure ground wires are secure.

CLUTCH

Disassembly:

The Cobra clutch is a high performance, adjustable racing clutch and requires periodic maintenance. To remove the clutch drain the engine transmission oil, remove the pipe and remove the 6 bolts that hold the kick-starter cover on. The clutch, clutch nut and drive gears are all assembled with a very high strength threadlocker and you must use heat from a small propane torch to remove these parts. Remove the clutch nut (right handed nut) on the end of the crankshaft with a 22mm wrench. Cobra offers a clutch nut socket tool for an impact wrench (part # MCMUTL01).

There are (3)-6mm clutch puller holes located on the ends of the center hub. (See drawing below) You must use a draw type puller to remove the clutch. Cobra also offers these pullers (part # MCMUTL68). This is a universal puller that pulls the clutch, main drive gear and rotor. **DO NOT** use a jaw type puller or the 6mm tapped holes as jackscrews or you will cause serious damage to the clutch drum or clutch.

When pulling the clutch, apply heat only to the center clutch hub. Do not heat the crankshaft threads or the aluminum shoes. Keep tension on the puller as you are heating it. Be careful because usually the clutch will pop off under tension from the puller and will be hot.

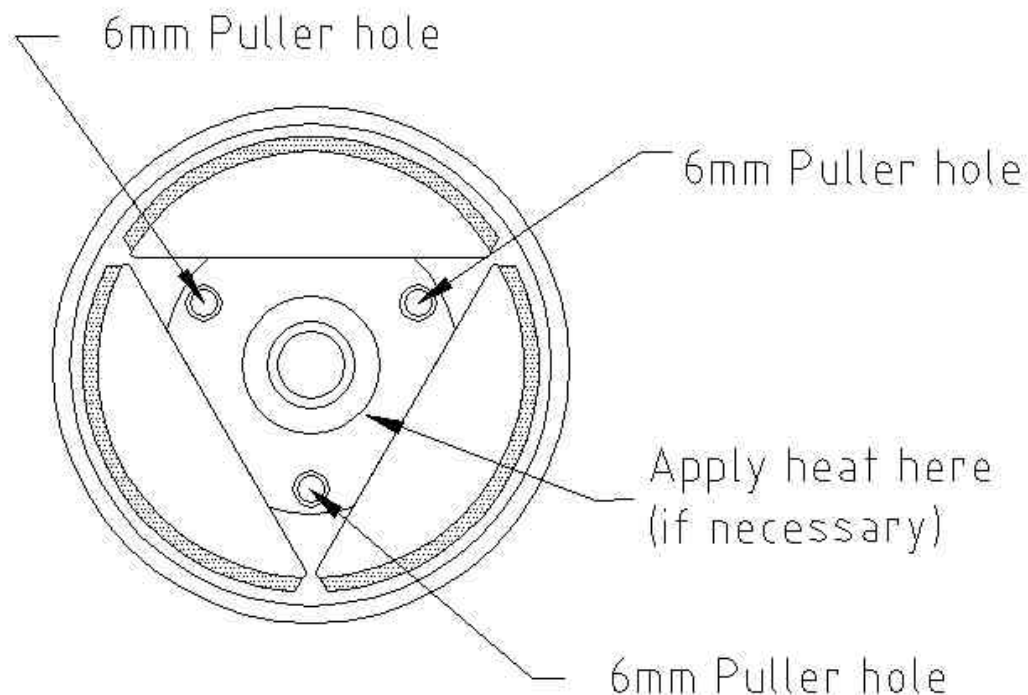

Once the clutch is off and cool to touch, carefully put it into a vice and remove the center shoulder bolt. You will probably have to heat the center hub again to remove the bolts. Once you get a bolt loosened, carefully remove it with the shoe and observe the way the spring washers are stacked. *This is very important.* (See drawing page 8)

CM CLUTCH ASSEMBLY REFERENCE DRAWING		
REF. #	PART #	DESCRIPTION
1	CAKG0002	CLUTCH - COMPLETE
2	CAKG0004	CLUTCH SPRING AND SHOE - SET OF 3
3	CAMU0008	CLUTCH SPRING - SET OF 3 (springs, washer, bolt)
4	CAKG0005	CLUTCH SHOE - SET OF 3
5	HCBS5603	CENTER SHOULDER BOLT

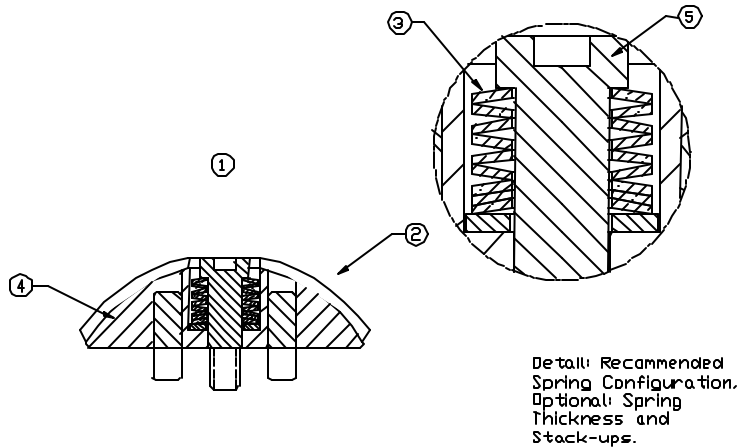

Clutch shoe wear:

If the clutch has been slipping and shows signs of glazing, it is best to replace the shoes. We have found that once the shoes are glazed, even if emery paper or a file removes the glaze engagement performance is reduced.

The best way to prevent glazing is by not gearing too high, changing the oil as specified and by not blipping the throttle. Every time you blip the throttle, you are working your clutch springs. Please keep in mind that the clutch produces a tremendous amount of heat and when a rider is blipping it, the clutch and clutch springs wear out quicker. Besides the fact it makes your engine want to run hotter and you lose power from a hot engine. So it is important to train your rider *not* to be a **throttle blipper**.

Sludge build-up between the spring washers also keeps the clutch shoe from engaging fully and this will cause the clutch to start to slip. So you will need to clean the sludge out or just replace the spring washers and bolts with new ones. How quickly this sludge builds up depends on how often you **change your oil** and whether your rider is a throttle blipper.

Reassembly-(clutch):

After cleaning or replacing the spring washers, it is very important to reassemble the stack up of washers in the same exact manner as they came apart. It is also important to clean the threads on the center shoulder bolt with a contact cleaner and you MUST use a high strength threadlocker. Tighten the center bolt as tight as possible without stripping the allen head. Do not drool threadlocker in the spring washers or on the clutch. Use fine emery paper on the center hole in the clutch and on the tapered section of the crankshaft. Apply a small amount of threadlocker to the center tapered section of the crankshaft. Put the clutch back in. (see assembly drawing below) Use threadlocker on the threads of the clutch nut. If you are using an impact socket, just zap it lightly with an air wrench to tighten it because there are only about 4 threads inside the nut and they can be easily stripped. If you are tightening it by hand, you can very carefully use a 3/4" piece of wooden dowel rod inside the exhaust port to block the piston so you can tighten the nut. Do not use something harder than your aluminum piston and do not crush the top of the piston into the ring. Put kick-starter and pipe back on and add oil.

ITEM NO.	PART NO.	DESCRIPTION
1	ECMU0017	CRANK SEAL
2	ECMU0029	THRUST WASHER (x2)
3	ECMU0028	THRUST BEARING
4	ECMU0041	CLUTCH DRUM
5	CAKG0002	CLUTCH COMPLETE w/ ARBOR
6	ECMU0018	CLUTCH NUT

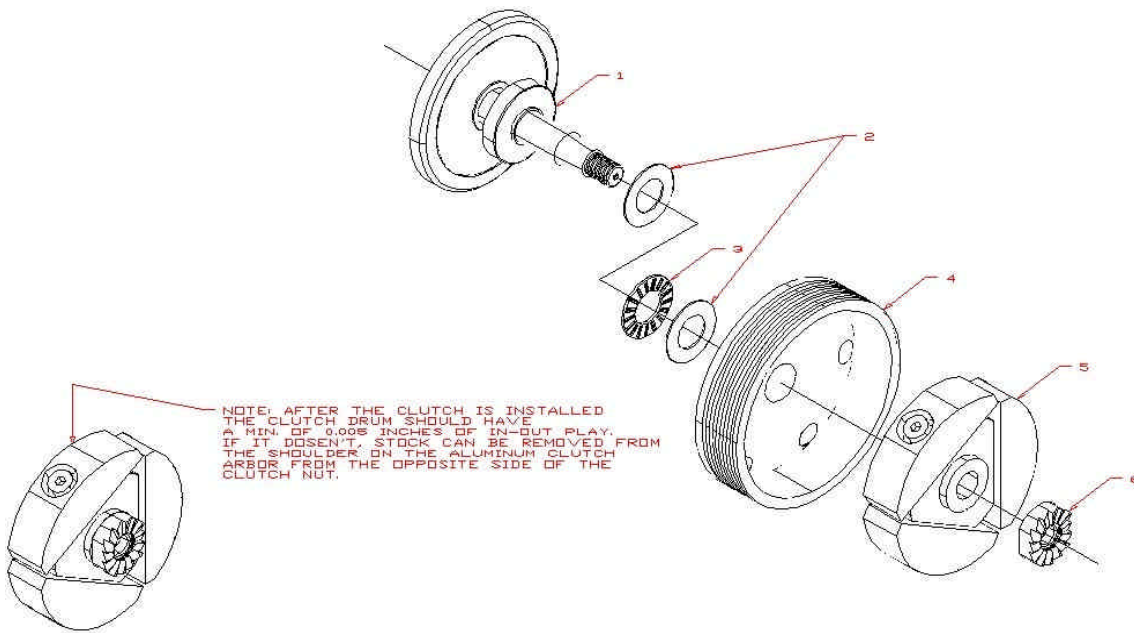

CARBURETOR

Your Cobra is equipped with an adjustable carburetor. Some fine-tuning may be needed according to weather condition and altitude. Make sure you allow the 6 hours of break-in time before doing any major carburetor adjustments. Proper jetting is *very* important for engine performance and engine life. Serious damage to the engine can occur if not properly adjusted.

IDLE ADJUSTMENT:

On the left side of the carburetor, there are 2 adjustment screws. The larger screw with the knurled head is the idle adjustment screw. To raise the idle, turn the screw in clockwise 1/4 turn at a time and rev the engine after each adjustment. To lower the idle, turn the screw counter-clockwise.

TOP END JETTING:

If the engine blubbers on the top end, you need to lean it out. (Blubbering means it won't sound crisp and cleaned out). Leaning it out can be done by raising the clip (this lowers the needle down) one notch at a time on the slide needle. Indications that the engine is running too lean are:

- Engine cutting out on top end
- Engine overheating
- White spark plug: When a carburetor is running lean, the fuel mixture is more air to gas. This results in a whiter looking spark plug reading.
- Engine seizure-

We recommend the engine be run a little on the richer side than on the lean side. In testing, we found the engine pulls harder and longer when it runs a little on the rich side.

To richen the carburetor, lower the clip of the needle one notch at a time until the engine starts to blubber on the top end, then move the clip up one notch or until you get the blubber out.

When a carburetor is running rich, the fuel mixture is more gas to air. This results in a blacker looking spark plug reading.

If you move your needle all the way up and all the way down and you can't get it richer or leaned enough, you will have to go to a larger or smaller main jet. Larger jet richens it, smaller leans it. Using an intake restrictor may tend to make the bike run leaner and you will probably need to richen the jetting.

BOTTOM/MID-RANGE JETTING (carb.):

The other, smaller brass screw that is towards the front of the engine is a fuel mixture screw. This screw will also richen and lean your engine more on the bottom and mid-range. In warmer conditions, turn the screw in. In colder conditions, turn the screw out. Be sure to keep the carburetor very clean and make sure you don't have water or dirt in the carburetor bowl. I use WD-40 to clean the carburetor inside and out. I don't recommend carburetor cleaner because I feel it is hazardous to your health.

	94-97 BM	97-00 CM	01 - 02 CM	98-99 King	'00 King	'01 King	'02 King
TIMING *	0.060	.045-.050	.040-.045	.040-.050	.040-.045	.040-.045	.040
MAIN JET**	80-82	82-85	82-85	90-91	92-96	90-94	96
PILOT JET*	55-60	55-60	55-60	55-60	50-60	55	50
HEAD TORQUE (inch-pounds)	100-110	100-110	100-110	100-115	100-115	100-110	100-110
SPARK PLUG GAP (in.)	.020-.025	.020-.025	.020-.025	.020-.025	.020-.025	.020-.025	.020-.025
SPARK PLUG	B8HV	B8HV	Split Fire SF406B	B9EV	B9EV	Split Fire SF406B	Split Fire SF406B
FORK OIL (oz) (10W fork oil)	4.5-5.0	4-4.5	4-4.5	5.5-6.0	4.0	4.0-4.5	4.0-4.5
TRANS. FLUID (cc ATF)	450	450	225	265	265	225	225

*Rotation Counter-clockwise; Before Top Dead Center

Because of different rider weights, sizes and riding styles, we offer optional shock valving and spring rate set-ups as follows.

Optional Suspension Components

SHOCK VALVING FOR THE 2000 CM50

40-50# rider	Part # SCCM4050
51-60# rider	Part # SCCM5160
61-70# rider	Part # SCCM6170

SHOCK VALVING FOR THE 2001

40-50# rider	Part # SCCM0100
51-60# rider	Part # SCCM0101
61-70# rider	Part # SCCM0102

SHOCK SPRINGS FOR THE 2000-01 CM50

200# spring	Part # SCCM0200
220# spring	Part # SCCM0220 (stock)
230# spring	Part # SCCM0230

SHOCK VALVING: '99 – 00 KING

SCKG4050 LIGHT FOR 40 – 50 LB RIDER
SCKG5160 MEDIUM FOR 51 – 60 LB RIDER
SCKG6170 HEAVY FOR 61 70 LB RIDER
SCKG7190 EX-HEAVY FOR 71 90 LB RIDER

SHOCK SPRINGS: '99 – 00 KING

155 LB/IN	SCKG0155
165 LB/IN	SCKG0165 STOCK
175 LB/IN	SCKG0175
185 LB/IN	SCKG0185

SHOCK VALVING FOR THE 2001 KING

40-50# rider	Part # SCKG0100
51-60# rider	Part # SCKG0101
61-70# rider	Part # SCKG0102

SHOCK SPRINGS FOR THE 2001 KING

155# spring	Part # SCKG0155 (yellow)
165# spring	Part # SCKG0165 (purple) stock
175# spring	Part # SCKG0175 (black)
185# spring	Part # SCKG0185 (white)

FORK SPRINGS FOR THE 1997-00 CM50

15# spring	Part # KCCM0004 (stock)
17# spring	Part # KCCM0301

FORK SPRINGS: 01 – 02 CM50, 98 – 99 KING

15# spring	Part # KCKG0002 (stock)
17# spring	Part # KCKG0003

FORK SPRINGS FOR THE 2000 & 2001 KING

7# spring	Part # KCKG0007
9# spring	Part # KCKG0009 (stock)
12# spring	Part # KCKG1200

OPTIONAL FORK BASE VALVING 2000 – 2002 KING

SOFT	KCKG0013
------	----------

MEDIUM
STIFF

KCKG0014
KCKG0015

STOCK

REAR SHOCK

1997 – 2002 CM SHOCK ASSEMBLY REFERENCE DRAWING						
REF. #	PART #	DESCRIPTION		REF. #	PART #	DESCRIPTION
1	SACM2001	SHOCK ASSEMBLY		16	HCWF0716	INTERNAL WASHER
2	SCMU0006	PRELOAD NUT		17	HCNJ7162	SHOCK SHAFT NUT
3	SCCM0220	SHOCK SPRING - 220#		18	SCCM0300	VALVE STACK (COMPR. & REBOUND)
	SCCM0200	SHOCK SPRING - 200#		19	SCMU0003	PISTON SLIDE BUSHING
	SCCM0230	SHOCK SPRING - 230#		20	ZCMUOR29	PISTON O-RING
4	SCMU0019	SPRING STOP		21	SCMU0002	SHOCK PISTON
5	SACM0004	SHAFT ASSEMBLY (Incl. Bottom Mount)		22	SCCM0022	SHOCK BODY
6	HCWF0058	SPRING STOP WASHER		23	SCMUSR11	SNAP RING - SEAL HEAD
7	SCMU0200	MOUNTING SPACER		24	SCMU0017	RETAINING RING
8	SCMU0202	MOUNTING BUSHING		25	ZCMUOR15	O-RINGS (MULTIPLE USE)
9	SCKG0001	SHOCK CANISTER		26	SAMU0001	SEAL HEAD ASSEMBLY
10	SCMU0014	SHOCK BLADDER		27	SCMU0004	VALVE CAP - STEEL
11	SCMU0005	CANISTER CAP		28	SCCM0100	TRANSPLANT (LIGHT)
12	SCMU0213	ELBOW JOINT - CANISTER			SCCM0101	TRANSPLANT (MEDIUM)
13	SCMU0024	BRAIDED HOSE - SHOCK			SCCM0102	TRANSPLANT (HEAVY)
14	SCMU0027	SHOCK BUMPER				
15	SCMU0114	NITROGEN INLET				

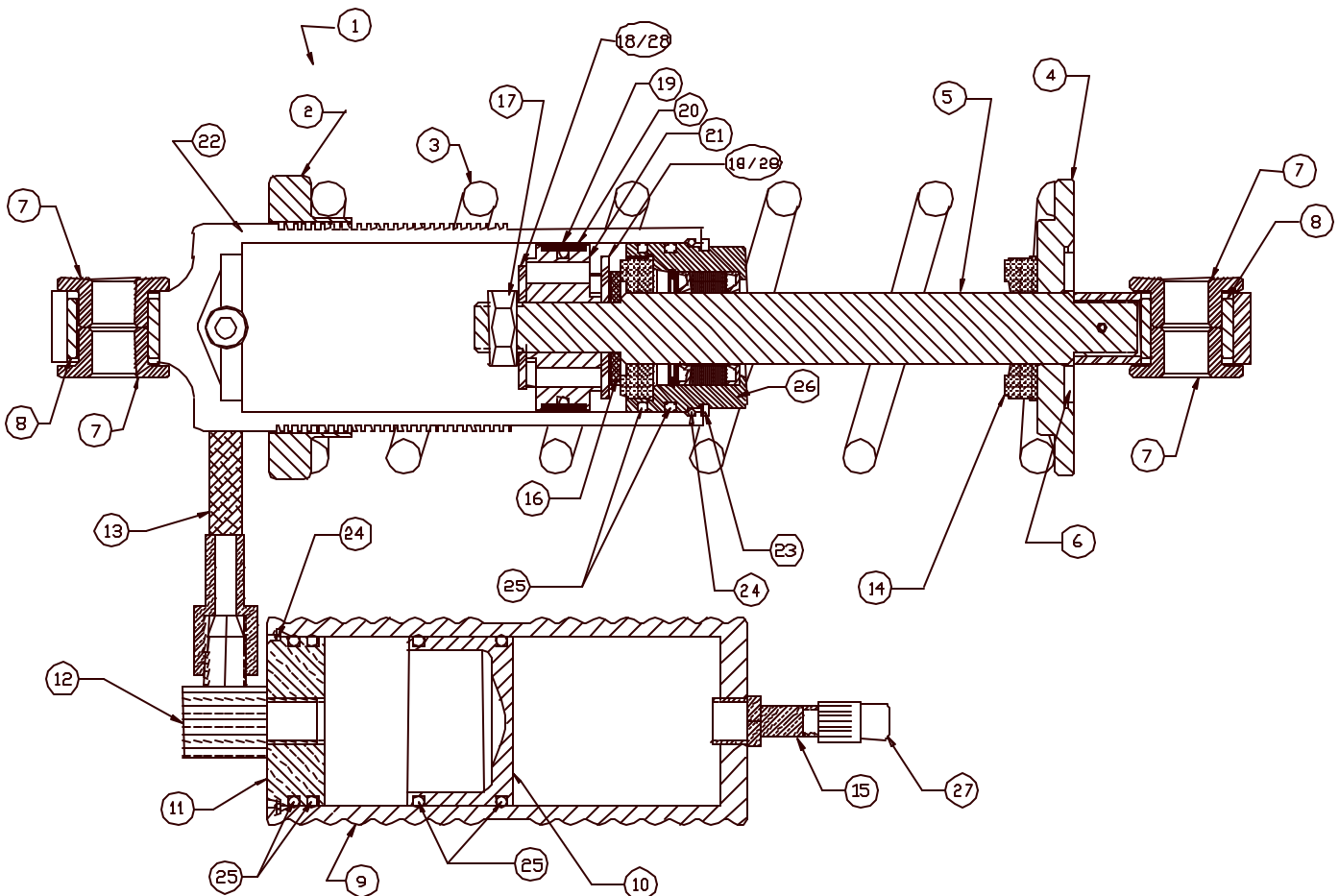

REAR SHOCK

2000 – 01 KING SHOCK ASSEMBLY REFERENCE DRAWING					
REF. #	PART #	DESCRIPTION	REF. #	PART #	DESCRIPTION
1	SAKG2001	SHOCK ASSEMBLY	15	SCMU0114	NITROGEN INLET
2	SCMU0006	PRELOAD NUT	16	HCWF0716	INTERNAL WASHER
3	SCKG0155	SHOCK SPRING - 155# - yellow	17	HCNJ7162	SHOCK SHAFT NUT
	SCKG0165	SHOCK SPRING - 165# - purple (stock)	18	SCKG0009	VALVE STACK (COMPR. & REBOUND)
	SCKG0175	SHOCK SPRING - 175# - black	19	SCMU0003	PISTON SLIDE BUSHING
	SCKG0185	SHOCK SPRING - 185# - white	20	ZCMUOR29	PISTON O-RING
4	SCMU0019	SPRING STOP	21	SCMU0002	SHOCK PISTON
5	SAKG0004	SHAFT ASSEMBLY (Incl. Bottom Mount)	22	SCKG0022	SHOCK BODY
6	HCWF0058	SPRING STOP WASHER	23	SCMUSR11	SNAP RING - SEAL HEAD
7	SCMU0200	MOUNTING SPACER	24	SCMU0017	RETAINING RING
8	SCMU0202	MOUNTING BUSHING	25	ZCMUOR15	O-RINGS (MULTIPLE USE)
9	SCKG0001	SHOCK CANISTER	26	SAMU2001	SEAL HEAD ASSEMBLY
10	SCMU0014	SHOCK BLADDER	27	SCMU0004	VALVE CAP - STEEL
11	SCMU0005	CANISTER CAP	28	SCKG0100	TRANSPLANT (LIGHT)
12	SCMU0213	ELBOW JOINT - CANISTER		SCKG0101	TRANSPLANT (MEDIUM)
13	SCMU0024	BRAIDED HOSE - SHOCK		SCKG0102	TRANSPLANT (HEAVY)
14	SCMU0027	SHOCK BUMPER			

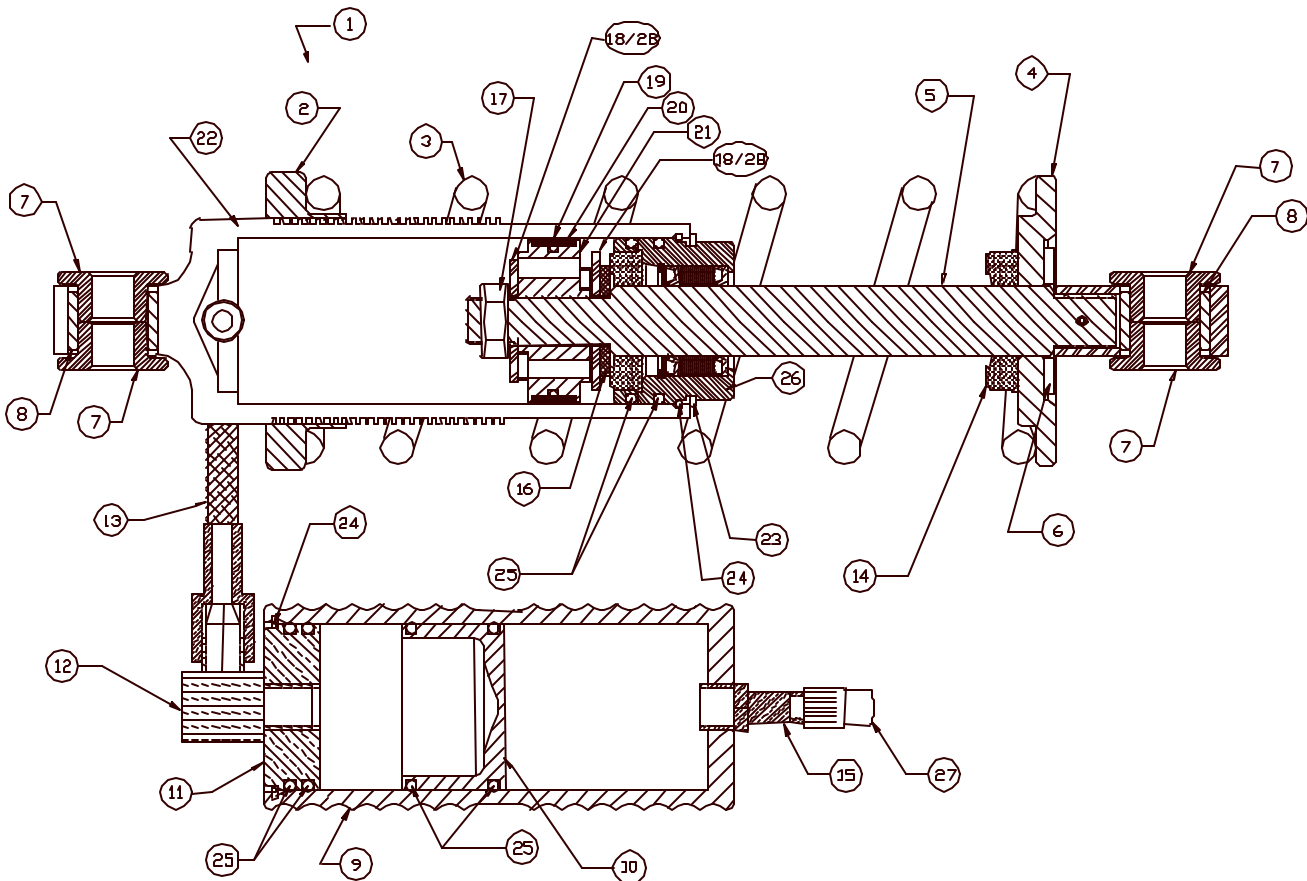

2002 King Shock	
COBRA PART NUMBER	DESCRIPTION
SCKGOH01	SPRING CLIP
SCKGOH02	SPACER
SCKGOH03	BALL JOINT
SCKGOH04	SPRING PLATFORM
SCKGOH05	LOCKNUT
SCKGOH06	SLEEVE
SCKGOH07	BUMPER RUBBER
SCKGOH09	SPRING-MEDIUM-STOCK
SCKGOH10	SPRING-HEAVY
SCKGOH11	ORING FOR BALL JOINT
SCKGOH12	ORING FOR REBOUND ADJUSTER
SCKGOH13	ORING FOR REBOUND ADJUSTER
SCKGOH14	SUPPORT SLEEVE
SCKGOH15	CIRCLIP
SCKGOH16	PIN FOR REBOUND ADJUST
SCKGOH17	ADJUSTMENT KNOB
SCKGOH18	SHAFT FOR END EYE
SCKGOH19	NUT
SCKGOH20	END EYE
SCKGOH21	SCREW FOR KNOB
SCKGOH22	KNOB FOR ADJUSTMENT

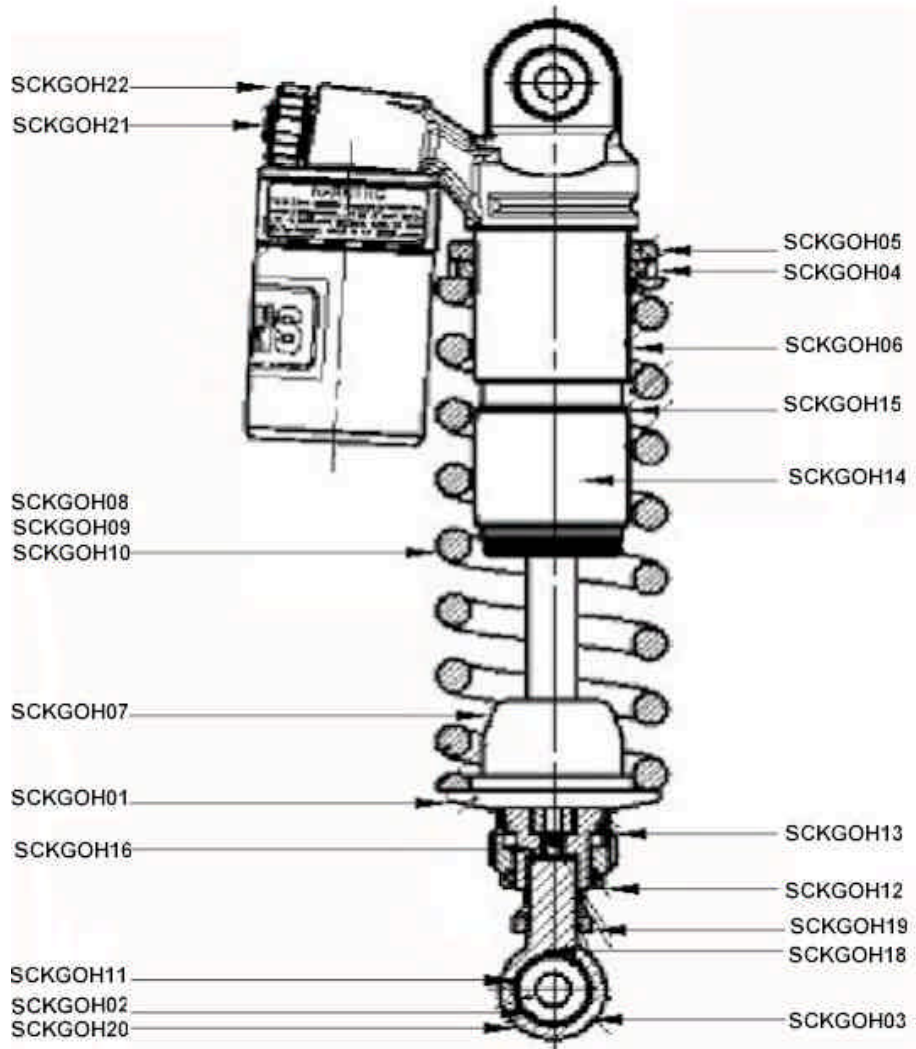

FRONT FORK

1997 – 2002 CM FORK ASSEMBLY REFERENCE DRAWING

REF. #	PART #	DESCRIPTION	REF. #	PART #	DESCRIPTION
1	HCWC0000	COPPER WASHER	13	KCMU0007	FORK SEAL - 1
2	KCMU0006	FORK CAP	14	KCMU0003	ANTI BOTTOM SPRING-REBOUND
3	ZCMUOR08	O-RING - FORK CAP	15	KCMU0005	DAMPER VALVE-1 PIECE
4	KCCM0006	FORK TUBE	16	KCMU0010	VALVE WASHER - #15
5	KCKG0002	FORK SPRING - 15#	17	KCMU0002	ANTI BOTTOM HOUSING
	KCKG0003	FORK SPRING - 17#	18	KCMUSR25	SNAP RING-INT, 1.000
6	FCMU0040	PISTON COMPRESSION RINGS-2	19	KCCM0003	DAMPER ROD
7	KCMU0009	COMPRESSION RING RETAINER TOP	20	KCCM0002	FORK LEG - NON-BRAKE SIDE
8	KCMU0001	COMPRESSION RING		KCCM0001	FORK LEG - BRAKE SIDE
9	KCMUSR17	SNAP RING - COMPR. STACK #17	21	KCMU0101	ANTI BOTTOM VALVE
10	HCBH1201	NUT - COMPR. STACK 1/2-20 HEX	22	HCBC0806	DAMPER ROD BOLT - 8X30 CS
11	KCMU0008	SWIPER - 1	23	KCMU0004	COMPR. STACK / DAMPER VALVE SET
12	KCMUSR23	SNAP RING-INT, 1-9/16			

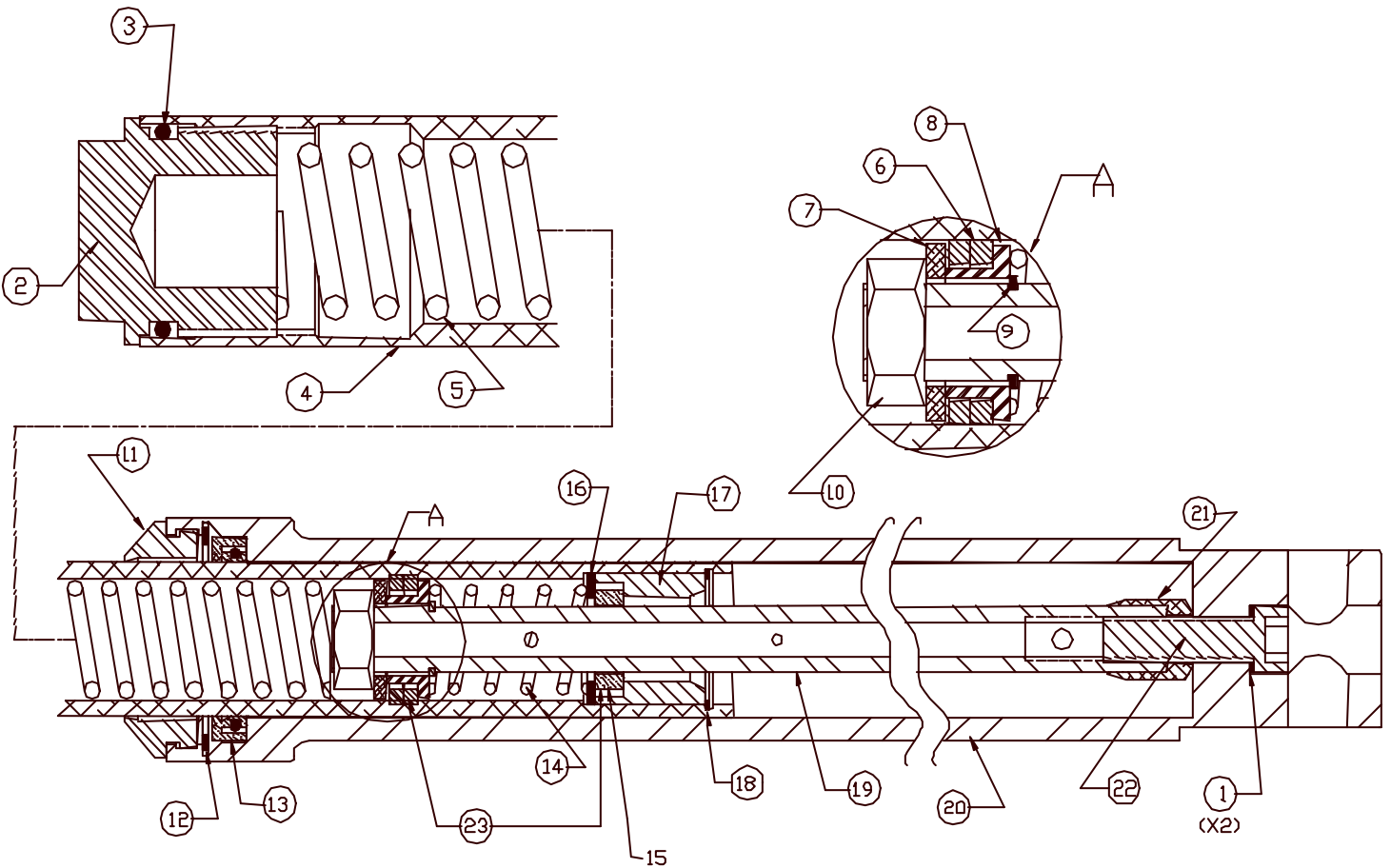

King Forks 2000 - 2002

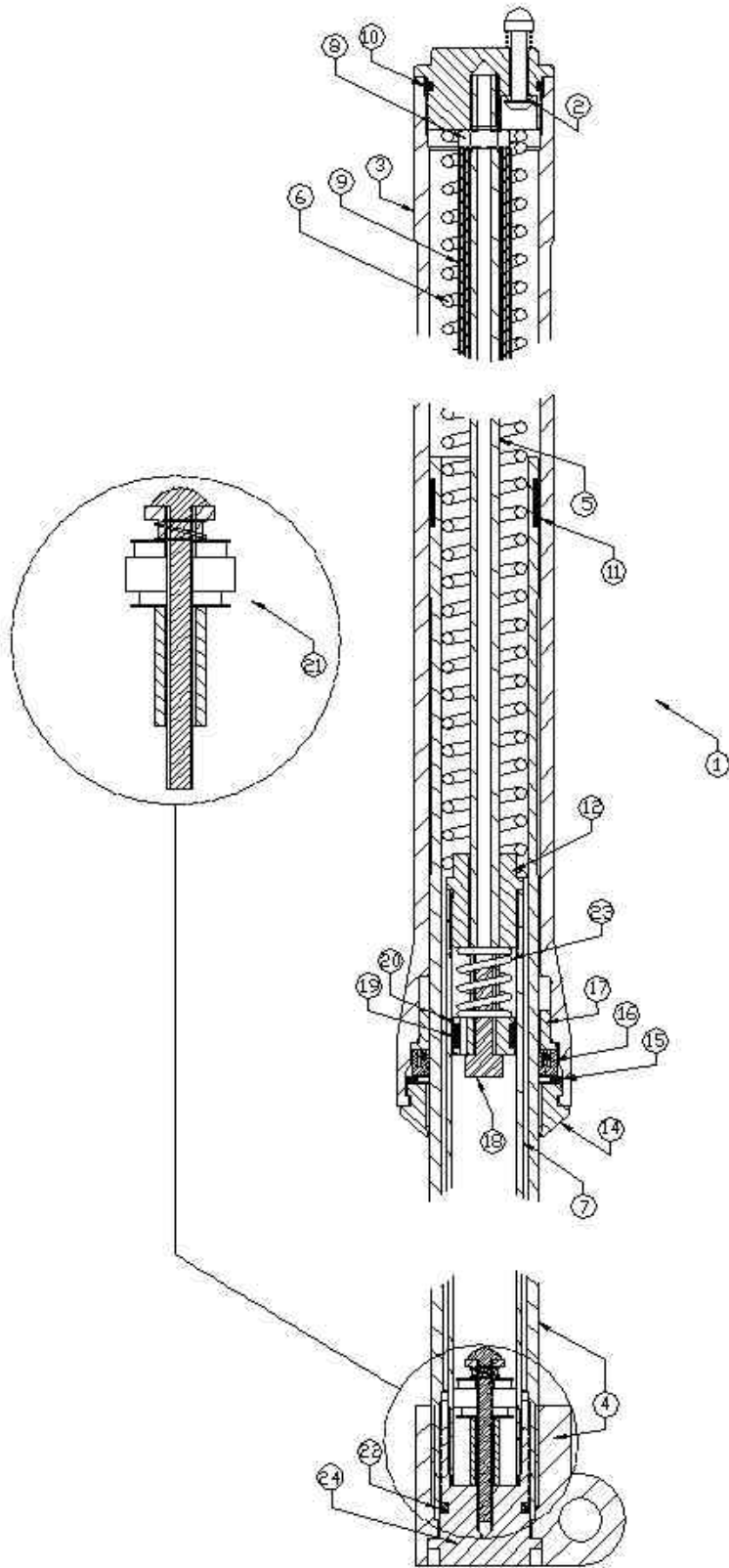

KING FORK Ref. Drawing		
REF. #	PART #	DESCRIPTION
1	KAKG0005	FORK ASSY. BRAKE SIDE
	KAKG0006	FORK ASSY. NON BRAKE SIDE
2	KAKG0030	FORK CAP
3	KCKG0021	FORK LEG - OUTER
4	KAKG0028	FORK LEG-INNER BRAKE SIDE
	KAKG0029	FORK LEG-INNER NON BRAKE SIDE
5	KCKG0027	DAMPER ROD
6	KCKG0007	FORK SPRING 7#
	KCKG0009	FORK SPRING 9# (STOCK)
	KCKG1200	FORK SPRING 12#
7	KCKG0023	CARTRIDGE TUBE
8	HCNL5601	LOCK NUT-FORK CAP
9	KCKG0032	FORK SPRING GUIDE
10	ZCMUOR08	O-RING FORK CAP
11	KCKG0033	FORK BUSHING-OUTER
12	KCKG0025	CARTRIDGE TOP
14	KCMU0008	SWIPER
15	KCMUSR23	SNAP RING
16	KCMU0007	FORK SEAL
17	KCKG0020	FORK BUSHING-INNER
18	HCBC0625	BOLT-DAMPER ROD
19	KCKG0035	BUSHING-PISTON
20	KCKG0026	FORK PISTON
21	KAKG0013	BASE VALVE ASSY.(SOFT)
	KAKG0014	BASE VALVE ASSY. MEDIUM (STOCK)
	KAKG0015	BASE VALVE ASSY.(HARD)
22	ZCKGOR10	O-RING - BASE VALVE ASSEMBLY
23	KCKG0031	TOP OUT SPRING
24	KCKG0024	FORK BOTTOM PLUG

Carburetor King 2000

CM Carburetor Ref. Drawing		
REF. #	PART #	DESCRIPTION
1	RCMU0305	CARB SLIDE
2	RCMU0601	NEEDLE
3	RCMU0002	ATOMIZER
4		MAIN JET
5		PILOT JET
6		CHOKE JET
7	RCMU0301	FLOAT
8	RCMU0102	RUBBER CABLE CAP SEAL
9	RCMU0003	CABLE ADJUSTER
10		
11	RCMU0006	TOP CARB SCREW
12	RCMU0106	CARB TOP
13	ZCMU0007	TOP CARB GASKET
14	RCMU0004	SLIDE SPRING
15	RCMU0205	NEEDLE RETAINER PLATE
16	RCMU0007	NEEDLE CLIP
17	RCMU0204	CHOKE ASS'Y. 2001 CM
17A	RCMU0701	CHOKE ASS'Y. 1997-00 CM
18		See #17/17a
19	RCMU0014	SLEEVE - PLASTIC CARB
20	RCMU0009	FUEL MIXTURE SCREW
21	RCMU0011	IDLE ADJUSTMENT SCREW
22		
23	RCMU0017	CLAMP ASSEMBLY
24		
25	RCMU0103	FLOAT BOWL GASKET
26	RCMU0107	FLOAT NEEDLE
27	RCMU0012	DIFFUSER
28	RCMU0016	FLOAT RETAINER PIN
29	RCMU0106	FLOAT BOWL
30	RCMU0201	BOTTOM FLOAT SCREW
31		
33		
33	RCMU0269	VELOCITY STACK

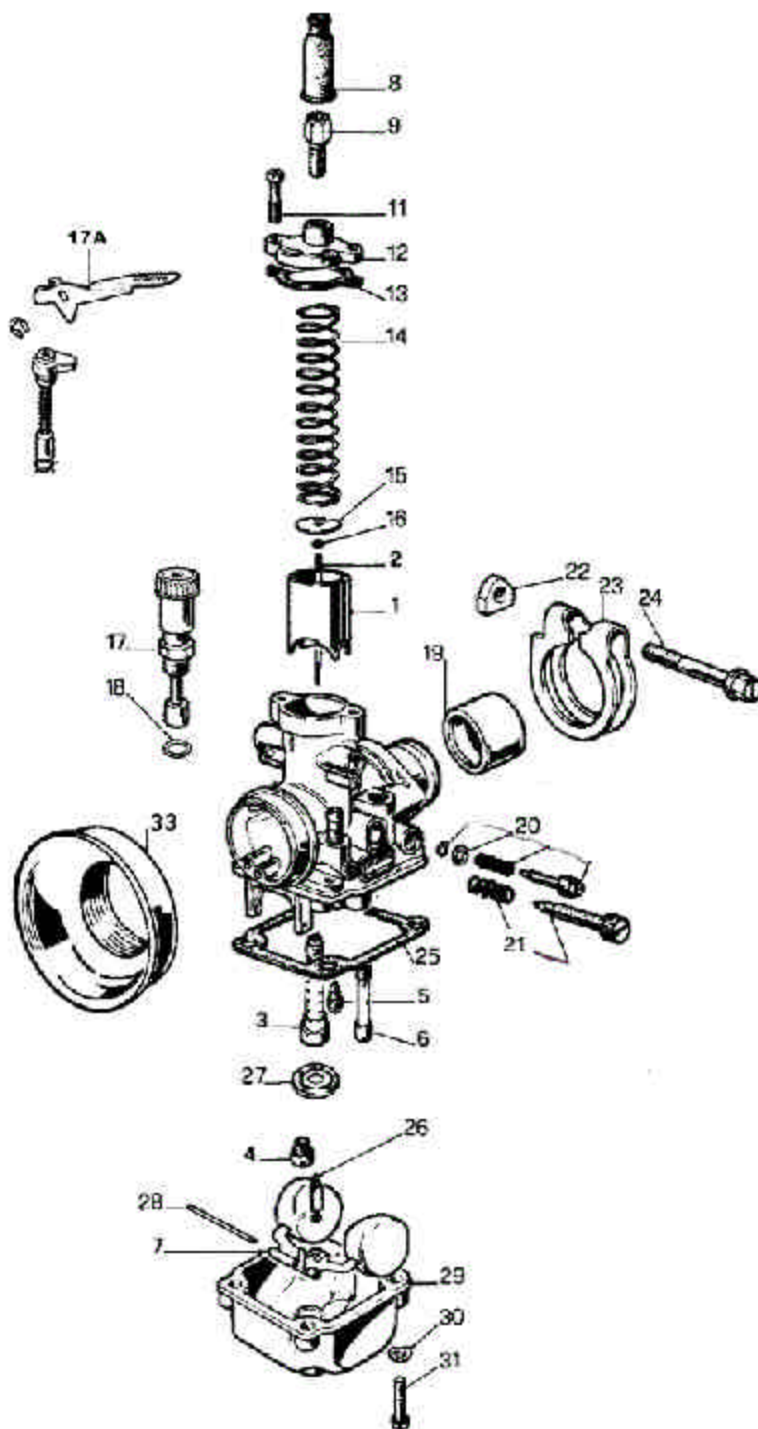

2001 – 2002 King

KING Carburetor Ref. Drawing		
REF. #	PART #	DESCRIPTION
1	RCMU0305	CARB SLIDE
2	RCMU0601	NEEDLE
3	RCMU0002	ATOMIZER
4		MAIN JET
5		PILOT JET
6		CHOKE JET
7	RCMU0301	FLOAT
8	RCMU0102	RUBBER CABLE CAP SEAL
9	RCMU0003	CABLE ADJUSTER
10		
11	RCMU0006	TOP CARB SCREW
12	RCMU0106	CARB TOP
13	ZCMU0007	TOP CARB GASKET
14	RCMU0004	SLIDE SPRING
15	RCMU0205	NEEDLE RETAINER PLATE
16	RCMU0007	NEEDLE CLIP
17	RCMU0204	CHOKE ASS'Y. 2001 CM
20	RCMU0009	FUEL MIXTURE SCREW
21	RCMU0011	IDLE ADJUSTMENT SCREW
25	RCMU0103	FLOAT BOWL GASKET
26	RCMU0107	FLOAT NEEDLE
27	RCMU0012	DIFFUSER
28	RCMU0016	FLOAT RETAINER PIN
29	RCMU0106	FLOAT BOWL
30	RCMU0201	BOTTOM FLOAT SCREW
31		
33	RCMU0269	VELOCITY STACK

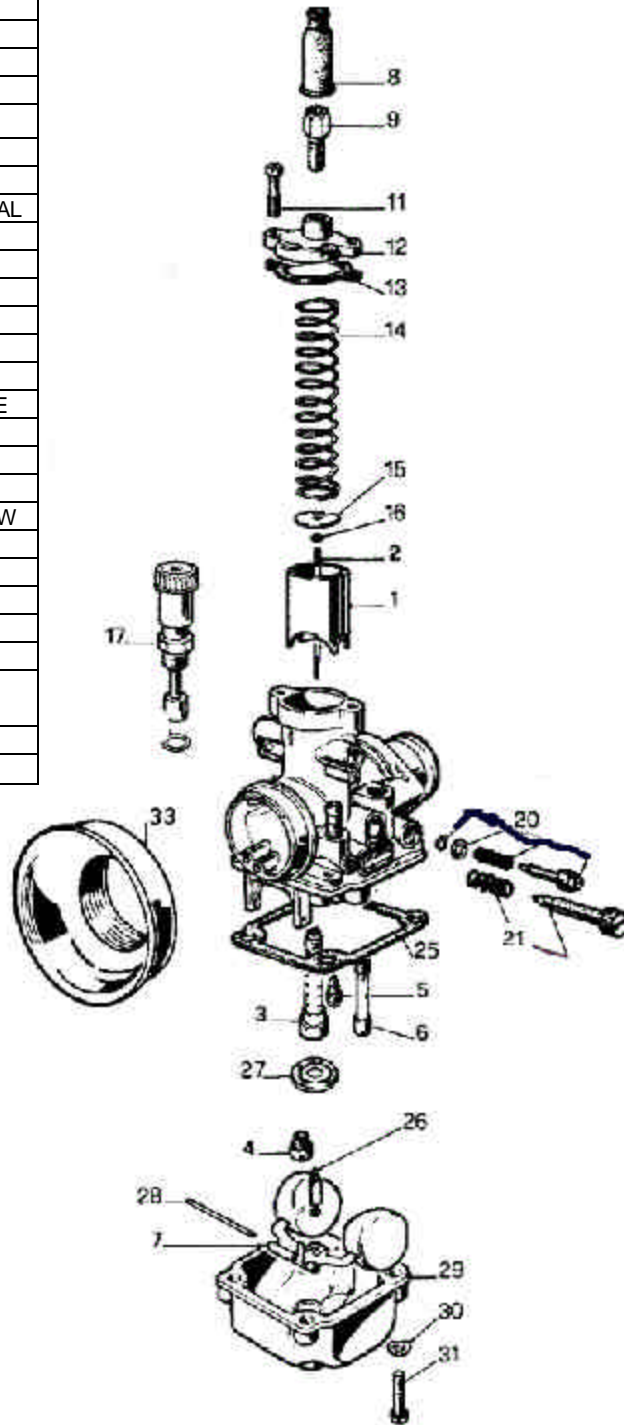

2001 2002 CM ENGINE ASSEMBLY REFERENCE DRAWING

REF. #	PART #	DESCRIPTION	REF. #	PART #	DESCRIPTION
1	CAKG0002	Clutch, Complete	44	ZCKG0002	Gasket, Base
2	CAKG0004	Shoes, Clutch w/ Washer Springs	45	ECKG0041	Cylinder, 50cc
3	CAMU0008	Spring Set, Washer type for Clutch	46	ZCMUOR07	Oring, Exhaust Flange
4	CCMU0031	Arbor for 3 Shoe Clutch	47	ECKG0015	Exhaust Flange
5	ECMU0018	Nut, Crankshaft Starter	48	HCBC0602	Screw, 6x20
6	ECMU0033	Clutch Hub w/ Gear	49	ECMU0008	Stud, Cylinder
7	ECMU0003	Bushing, for Clutch Hub, Brass	50	ZCMUOR03	Oring, Cylinder head, Small
8	ECMU0040	Spacer, Clutch to Hub	51	ZCMUOR05	Oring, Cylinder head, Medium
9	ECMU0017	Seal, Crankshaft	52	ECKG0021	Cylinder Head Dome-Insert
10	ECMU0016	Bearing, Crankshaft	53	HCWF0601	Washer, 6mm
11	ECMU0001	Bearing, Trans., Secondary Gear	54	HCNS1401	Nut, 1/4-20
12	ECMU0020	Bearing, Trans., Precision	55	ZCMUOR02	Oring, Cylinder head, Large
13	ECMU0105	Gear, Trans., Primary	56	ZCMUOR08	Oring, Cylinder head
14	HCNS1202	Nut, 1/2-20, Left Hand	56A	ZAKGOR02	Oring Kit, Top End
15	ECKG0014	Crankcase, Clutch side	57	ECKG0025	Cylinder Head - Outer Cap
16	ECKG0131	Fitting, Elbow, Water	58	HCWF1401	Washer, 1/4"
17	HCPP1801	Plug, 1/8"	59	ICMU0006	Rotor
18	ECMU0103	Shaft, Trans., Secondary w/gear	60	ICMU0007	Stator
19	ECMU0104	Shaft, Trans., Output w/gear	60A	MCKGGR00	Grommet, Engine case
20	ECKGBR01	Bearing, Trans., Output shaft	61	ECKG0073	Impeller, Waterpump
21	ZCKG9902	Gasket, Crankcase	62	ECKG0074	Seal, Waterpump
22	ECKG0071	Dowel, for Engine Cases	63	ECMU0032	Intake Manifold
23	ECMU0038	Crankshaft, Welded and Balanced	64	ECMU0049	Gasket, Reed case
24	ECKG0013	Crankcase, Ignition side	65	ECMU0050	Reed Stuffer
25	ECKG0004	Snap Ring, Int. for Water Pump	66	ECMU0047	Reed Assembly
26	ECKGSE01	Seal, Output shaft	66A	ECCM0002	Reeds, Metal
27	HCBC0606	Screw, M6x45	67	ZCKG0101	Gasket, Ignition Cover
28	HCBC0604	Screw, M6x35	68	ECKG0001	Cover, Ignition
28A	HCBC0603	Screw, M6x30	69	HCBC0802	Screw, 8-32x1-3/4
29	HCBC0608	Screw, M6x55	70	ECMU0043	Piston Kit
30	PCKG0013	Sprocket, 13T for output shaft	70A	ECMU0055	Piston Ring
30A	ECKGSR03	Snap Ring, ext. for output shaft	71	ECKG0012	Wrist pin
31	HCWP0001	Washer, Stator	72	ECMU0077	Bearing, Wrist Pin
32	HCBH0803	Screw, 8-32x7/8	73	ECMUSR00	Snap Ring for Piston
33	HCBC0801	Screw, 8-32x1-1/2	74	ECMUSP01	Spring, Kick Start Dog
34	HCNS1001	Nut, 10mm	75	ECMU0207	Gear, Kickstarter, Small
35	ECKG0042	Pulley, Waterpump-Crank	76	ZCMU0030	Gasket, Clutch Cover
36	ECKG0070	Belt, Waterpump	77	ECMU0205	Kick Starter Rubber
37	HCBB0001	Screw, 10-32x1/2"	78	HCWC0000	Gasket, Copper
37A	HCBC1033	Screw, 10-32x3/4"	79	HCBH0805	Screw, M8x12mm
38	HCWL0001	Washer, #10 starlock, internal tooth	80	ECMU0204	Kick Starter Dust Shield
39	ECMU0080	Belt Retainer	81	ZCMU0001	Gasket, Oil fill plug
40	ECKG0075	Pulley, Waterpump-Fan	82	ECMU0037	Oil fill plug
41	HCSS8201	Screw, 8-32x3/8	83	ECMU0202	Kickstarter Lever
42	ECKG0072	Bearing, Waterpump	84	ECMU0206	Kickstarter, complete
43	ECKG0141	Shaft, Waterpump	85	ECMU0403	Spring, Kickstarter Return

2001 KING

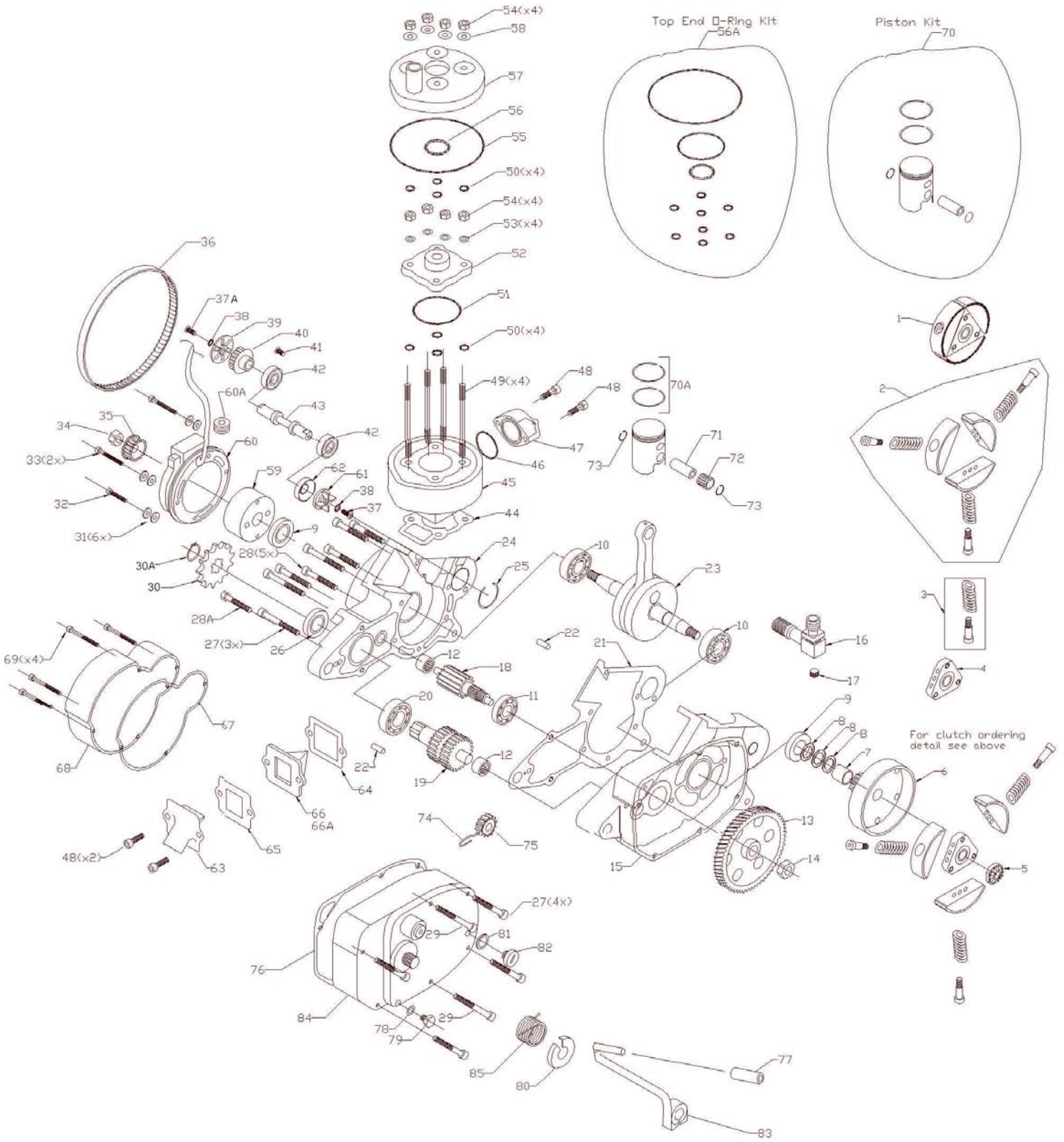

2001 KING ENGINE ASSEMBLY REFERENCE DRAWING

REF. #	PART #	DESCRIPTION	REF. #	PART #	DESCRIPTION
1	CAKG0002	Clutch, Complete	44	ZCKG0002	Gasket, Base
2	CAKG0004	Shoes, Clutch w/ Washer Springs	45	ECKG0041	Cylinder, 50cc
3	CAMU0008	Spring Set, Washer type for Clutch	46	ZCMUOR07	Oring, Exhaust Flange
4	CCMU0031	Arbor for 3 Shoe Clutch	47	ECKG0015	Exhaust Flange
5	ECMU0018	Nut, Crankshaft Starter	48	HCBC0602	Screw, 6x20
6	ECMU0033	Clutch Hub w/ Gear	49	ECMU0008	Stud, Cylinder
7	ECMU0003	Bushing, for Clutch Hub, Brass	50	ZCMUOR03	Oring, Cylinder head, Small
8	ECMU0040	Spacer, Clutch to Hub	51	ZCMUOR05	Oring, Cylinder head, Medium
9	ECMU0017	Seal, Crankshaft	52	ECKG0021	Cylinder Head Dome-Insert
10	ECMU0016	Bearing, Crankshaft	53	HCWF0601	Washer, 6mm
11	ECMU0001	Bearing, Trans., Secondary Gear	54	HCNS1401	Nut, 1/4-20
12	ECMU0020	Bearing, Trans., Precision	55	ZCMUOR02	Oring, Cylinder head, Large
13	ECMU0105	Gear, Trans., Primary	56	ZCMUOR08	Oring, Cylinder head
14	HCNS1202	Nut, 1/2-20, Left Hand	56A	ZAKGOR02	Oring Kit, Top End
15	ECKG0018	Crankcase, Clutch side	57	ECKG0025	Cylinder Head - Outer Cap
16	ECKG0131	Fitting, Elbow, Water	58	HCWF1401	Washer, 1/4"
17	HCPP1801	Plug, 1/8"	59	ICMU0006	Rotor
18	ECMU0103	Shaft, Trans., Secondary w/gear	60	ICMU0007	Stator
19	ECMU0104	Shaft, Trans., Output w/gear	60A	MCKGGR00	Grommet, Engine case
20	ECKGBR01	Bearing, Trans., Output shaft	61	ECKG0073	Impeller, Waterpump
21	ZCKG2001	Gasket, Crankcase	62	ECKG0074	Seal, Waterpump
22	ECKG0071	Dowel, for Engine Cases	63	ECKG0203	Intake Manifold
23	ECMU0038	Crankshaft, Welded and Balanced	64	ZCMU0032	Gasket, Reed to case
24	ECKG0017	Crankcase, Ignition side	65	ZCMU0031	Gasket, Intake to Reed
25	ECKG0004	Snap Ring, Int. for Water Pump	66	ECKG0202	Reed Assembly
26	ECKGSE01	Seal, Output shaft	66A	ECKG0204	Reed Kit
27	HCBC0606	Screw, M6x45	67	ZCKG0101	Gasket, Ignition Cover
28	HCBC0604	Screw, M6x35	68	ECKG0001	Cover, Ignition
28A	HCBC0603	Screw, M6x30	69	HCBC0802	Screw, 8-32x1-3/4
29	HCBC0608	Screw, M6x55	70	ECMU0043	Piston Kit
30	PCKG0013	Sprocket, 13T for output shaft	70A	ECMU0055	Piston Ring
30A	ECKGSR03	Snap Ring, Ext., for output shaft	71	ECKG0012	Wrist pin
31	HCWP0001	Washer, Stator	72	ECMU0077	Bearing, Wrist Pin
32	HCBH0803	Screw, 8-32x7/8	73	ECMUSR00	Snap Ring for Piston
33	HCBC0801	Screw, 8-32x1-1/2	74	ECMUSP01	Spring, Kick Start Dog
34	HCNS1001	Nut, 10mm	75	ECMU0207	Gear, Kickstarter, Small
35	ECKG0042	Pulley, Waterpump-Crank	76	ZCMU0030	Gasket, Clutch Cover
36	ECKG0070	Belt, Waterpump	77	ECMU0205	Kick Starter Rubber
37	HCBB0001	Screw, 10-32x1/2"	78	HCWC0000	Gasket, Copper
37A	HCBC1033	Screw, 10-32x3/4"	79	HCBH0805	Screw, M8x12mm
38	HCWL0001	Washer, #10 starlock, internal tooth	80	ECMU0204	Kick Starter Dust Shield
39	ECMU0080	Belt Retainer	81	ZCMU0001	Gasket, Oil fill plug
40	ECKG0075	Pulley, Waterpump-Fan	82	ECMU0037	Oil fill plug
41	HCSS8201	Screw, 8-32x3/8	83	ECMU0202	Kickstarter Lever
42	ECKG0072	Bearing, Waterpump	84	ECMU0206	Kickstarter, complete
43	ECKG0141	Shaft, Waterpump	85	ECMU0403	Spring, Kickstarter Return

2002 KING ENGINE ASSEMBLY REFERENCE DRAWING

REF. #	PART #	DESCRIPTION	REF. #	PART #	DESCRIPTION
1	CAKG0002	Clutch, Complete	44	ZCKG0002	Gasket, Base
2	CAKG0004	Shoes, Clutch w/ Washer Springs	45	ECKG0041	Cylinder, 50cc
3	CAMU0008	Spring Set, Washer type for Clutch	46	ZCMUOR07	Oring, Exhaust Flange
4	CCMU0031	Arbor for 3 Shoe Clutch	47	ECKG0015	Exhaust Flange
5	ECMU0018	Nut, Crankshaft Starter	48	HCBC0602	Screw, 6x20
6	ECMU0041	Clutch Hub w/ Gear	49	ECMU0008	Stud, Cylinder
7	ECMU0028	Thrust Washer	50	ZCMUOR03	Oring, Cylinder head, Small
8	ECMU0040	Thrust Bearing	51	ZCMUOR05	Oring, Cylinder head, Medium
9	ECMU0017	Seal, Crankshaft	52	ECKG0021	Cylinder Head Dome-Insert
10	ECMU0016	Bearing, Crankshaft	53	HCWF0601	Washer, 6mm
11	ECMU0001	Bearing, Trans., Secondary Gear	54	HCNS1401	Nut, 1/4-20
12	ECMU0020	Bearing, Trans., Precision	55	ZCMUOR02	Oring, Cylinder head, Large
13	ECMU0105	Gear, Trans., Primary	56	ZCMUOR08	Oring, Cylinder head
14	HCNS1202	Nut, 1/2-20, Left Hand	56A	ZAKGOR02	Oring Kit, Top End
15	ECKG0018	Crankcase, Clutch side	57	ECKG0025	Cylinder Head - Outer Cap
16	ECKG0131	Fitting, Elbow, Water	58	HCWF1401	Washer, 1/4"
17	HCPP1801	Plug, 1/8"	59	ICMU0006	Rotor
18	ECMU0103	Shaft, Trans., Secondary w/gear	60	ICMU0007	Stator
19	ECMU0104	Shaft, Trans., Output w/gear	60A	MCKGGR00	Grommet, Engine case
20	ECKGBR01	Bearing, Trans., Output shaft	61	ECKG0073	Impeller, Waterpump
21	ZCKG2001	Gasket, Crankcase	62	ECKG0074	Seal, Waterpump
22	ECKG0071	Dowel, for Engine Cases	63	ECKG0203	Intake Manifold
23	ECMU0038	Crankshaft, Welded and Balanced	64	ZCMU0032	Gasket, Reed to case
24	ECKG0017	Crankcase, Ignition side	65	ZCMU0031	Gasket, Intake to Reed
25	ECKG0004	Snap Ring, Int. for Water Pump	66	ECKG0202	Reed Assembly
26	ECKGSE01	Seal, Output shaft	66A	ECKG0205	Reed Kit
27	HCBC0606	Screw, M6x45	67	ZCKG0101	Gasket, Ignition Cover
28	HCBC0604	Screw, M6x35	68	ECKG0001	Cover, Ignition
28A	HCBC0603	Screw, M6x30	69	HCBC0802	Screw, 8-32x1-3/4
29	HCBC0608	Screw, M6x55	70	ECMU0043	Piston Kit
30	PCKG0013	Sprocket, 13T for output shaft	70A	ECMU0055	Piston Ring
30A	ECKGSR03	Snap Ring, Ext., for output shaft	71	ECKG0012	Wrist pin
31	HCWP0001	Washer, Stator	72	ECMU0077	Bearing, Wrist Pin
32	HCBH0803	Screw, 8-32x7/8	73	ECMUSR00	Snap Ring for Piston
33	HCBC0801	Screw, 8-32x1-1/2	74	ECMUSP01	Spring, Kick Start Dog
34	HCNS1001	Nut, 10mm	75	ECMU0207	Gear, Kickstarter, Small
35	ECKG0042	Pulley, Waterpump-Crank	76	ZCMU0030	Gasket, Clutch Cover
36	ECKG0070	Belt, Waterpump	77	ECMU0205	Kick Starter Rubber
37	HCBB0001	Screw, 10-32x1/2"	78	HCWC0000	Gasket, Copper
37A	HCBC1033	Screw, 10-32x3/4"	79	HCBH0805	Screw, M8x12mm
38	HCWL0001	Washer, #10 starlock, internal tooth	80	ECMU0204	Kick Starter Dust Shield
39	ECMU0080	Belt Retainer	81	ZCMU0001	Gasket, Oil fill plug
40	ECKG0075	Pulley, Waterpump-Fan	82	ECMU0037	Oil fill plug
41	HCSS8201	Screw, 8-32x3/8	83	ECMU0202	Kickstarter Lever
42	ECKG0072	Bearing, Waterpump	84	ECMU0206	Kickstarter, complete
43	ECKG0141	Shaft, Waterpump	85	ECMU0403	Spring, Kickstarter Return

COBRA IMPELLER SERVICE INSTRUCTIONS

1999-2002 King, 2001 & 02 CM

- 1. Remove exhaust pipe and gas tank (you will be using a propane torch in step 11).**
2. Remove radiator cap and drain engine coolant by removing 3/16" socket head drain plug. (Figure 1 – item 1).
3. If the impeller is damaged or broken completely back flush the coolant system to ensure no solid pieces are in the system.
4. Drain engine transmission oil by removing drain screw using a 13mm- hex wrench. (Figure 1 – item 2).
5. Remove kickstarter cover using a 5mm hex key. (Figure 1 – item 3 (6) places)
6. Unscrew both upper and lower water elbow fitting. (Figure 1 – item 4)



Figure 1

7. Remove ignition cover using a 9/64" hex key. (4) places
8. Remove belt retainer screw using a 1/8" hex key. (Figure 2 – item 1)
9. Remove belt retainer, waterpump belt and waterpump fan pulley.
10. Remove bearing retainer screw using a 3/32" hex key. (Figure 2 – item 2)

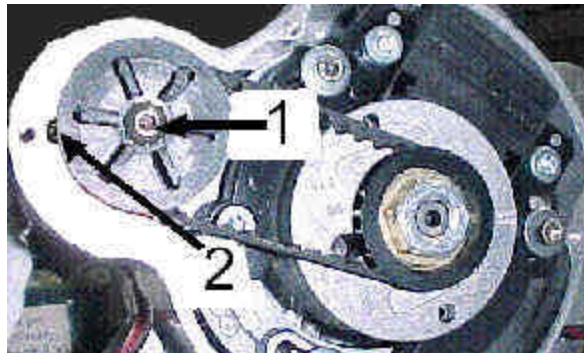

Figure 2

11. Heat engine case around area of impeller lightly with a propane torch. Using a 3/8" diameter x 8" long steel rod, tap impeller assembly out of engine as shown in figure 3.

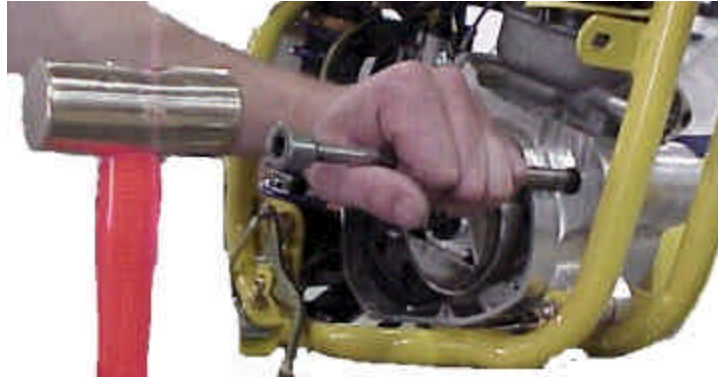

Figure 3

12. The shaft assembly is serviceable. Use a 1/8" hex key to remove impeller retainer screw. Remove impeller, seal and both bearings. Check shaft for wear in the area of the seal. If there is any sign of wear (like a groove) replace the shaft.



13. Reinstall new bearings, seal and impeller. Clean all threads and use Cobra threadlocker #MCMULT01.

14. Reinstall bearing assembly by using a 0.500" ID by 1.000" OD steel tube 2" long and tap on end of tube per figure 4. Liberally grease outside of seal, bearings and inside of case before installing.

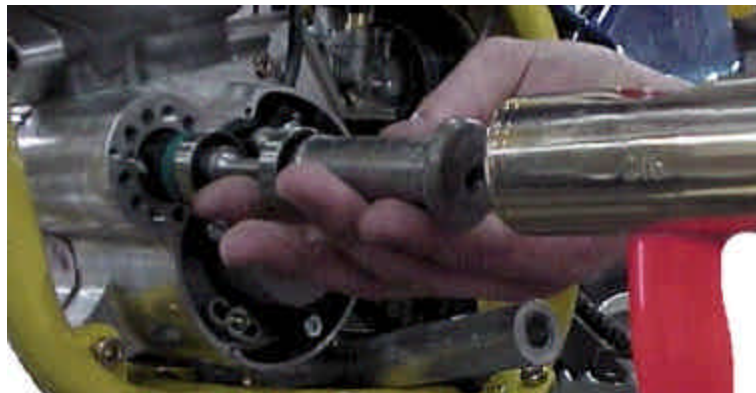

Figure 4

15. Re-assemble in same order of disassembly. Clean all threads and use Cobra threadlocker #MCMULT01 on the belt retainer screw.